



319 SERIES

PRESSURE/VACUUM

(DC VOLTAGE)

BASE MODELS

12V DC Voltage

3191250IRBLSCE

3D191250IRSLSCCE

(Dryer/solenoid equipped)



319 Series



3D19 Series

CUSTOM CONFIGURED OPTION

- 24V DC motor
- Stroke (Flow and/or pressure)
- Air dryer
- Dump solenoid
- Shock mount

FEATURES (BENEFITS)

- Black epoxy coated compressor exterior (Corrosion resistance)
- Oil-less operation (Clean air stream, less maintenance)
- Permanently lubricated bearings (Optimum life)
- Stainless steel inlet valve (Consistent performance, corrosion resistance)
- PTFE piston ring (Optimum life)
- Die-cast aluminum components (Strong, lightweight, durable)
- Coated steel mounting brackets with vibration isolators (Ease of component integration)
- Wetted parts treated for corrosion resistance (Optimum life, consistent performance)
- Dynamically balanced (Low operating vibration)
- Thermally protected motor (Fail-safe operation)
- Designed and tested per Agency standards (Fail-safe operation)
- Inlet filter/exhaust muffler (Quiet, clean operation)
- RoHS compliant (Green, eco-friendly)
- Radiated Emissions Suppression ECE-R10-03 (Interference free operation)

Declaration documentation available upon request

Qualified OEM designers should consult factory for purchase or custom configurations

- 920-457-4891 or td.usa@gardnerdenver.com
- Minimum order quantities may apply

Thomas Division is an ISO 9001 registered company

THOMAS
A Gardner Denver Product

**WOB-L[®]****319 Series Base Models****THOMAS**
A Gardner Denver Product

Max. flow 1.27 cfm (35.4 l/min)
Max. int. pressure 120 psi (8.3 bar)
Max. vacuum 93% local barometer

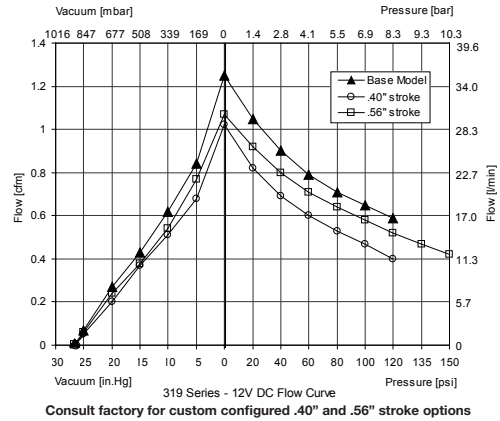
**319**Available in
12 or 24 volt DC**OIL-LESS****3D19**

Base Model Number	3191250IRBLSCE	3D191250IRSLSCE
Performance Data		
Head configuration	Pressure/vacuum	Pressure
Stroke	0.50 in (12.7 mm)	0.50 in (12.7 mm)
Nominal voltage	12V DC [24V DC]	12V DC [24V DC]
Maximum open air flow	1.25 cfm (35.4 l/min)	1.27 cfm (35.4 l/min)
Maximum rated intermittent pressure	120 psi (8.3 bar)	120 psi (8.3 bar)
Current at rated pressure	19.4A [8.9A]	19.7A [9.0A]
Power at rated pressure	233W [108W]	236W [108W]
Speed at rated pressure	3173 rpm [3035rpm]	3261 rpm [3123 rpm]
Maximum duty cycle at 100 psi at 23°C	8.5 minutes on, 20 minutes off	8.5 minutes on, 20 minutes off
Maximum pressure restart	120 psi (8.3 bar)	120 psi (8.3 bar)
Maximum vacuum	93% local barometer	Not available
Maximum vacuum restart	Max. vacuum	Not available

Electrical Data		
Motor type	Permanent Magnet	Permanent Magnet
Locked rotor current	134.0A [69.0A]	134.0A [69.0A]
Motor insulation class	B	B
Thermal switch	Yes	Yes
Motor lead wire color, gauge	Red/black, 14 AWG	Red/black, 14 AWG
Solenoid wire color, gauge	- -	Blue/white, 18 AWG

General Data		
Operating ambient air temperature	-40°F to 158°F (-40°C to 70°C)	-40°F to 158°F (-40°C to 70°C)
Safety certification	TUVE11	TUVE11
Net weight	5.1 lbs (2.3 kg)	6.4 lbs (2.9 kg)

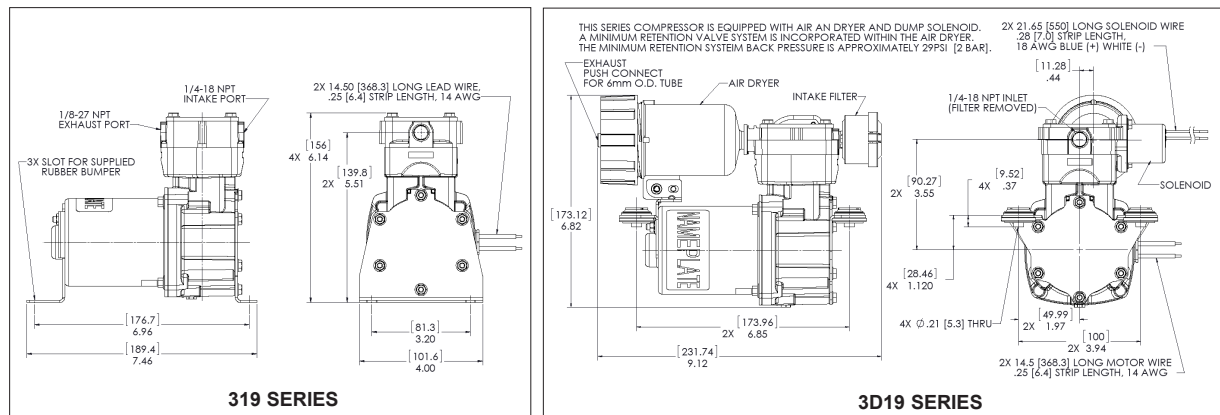
Product Dimensions Dual Dimensions: in[mm]**319 SERIES**

©2011 Gardner Denver Thomas, Inc.
 All rights reserved.
 Form No. 850-4003 11/14

The information presented in this material is based on technical data and test results of nominal units. It is believed to be accurate and reliable and is offered as an aid to help in the selection of Thomas Division products. It is the responsibility of the user to determine the suitability of the product for its intended use and the user assumes all risk and liability whatsoever in connection therewith. Thomas Division does not warrant, guarantee or assume any obligation or liability in connection with this information. **NOTE:** Models pictured are representative of the series and do not represent a specific model number. Consult factory for detailed physical description.